

Trane CRHR Compressors Terminal Wiring Diagrams

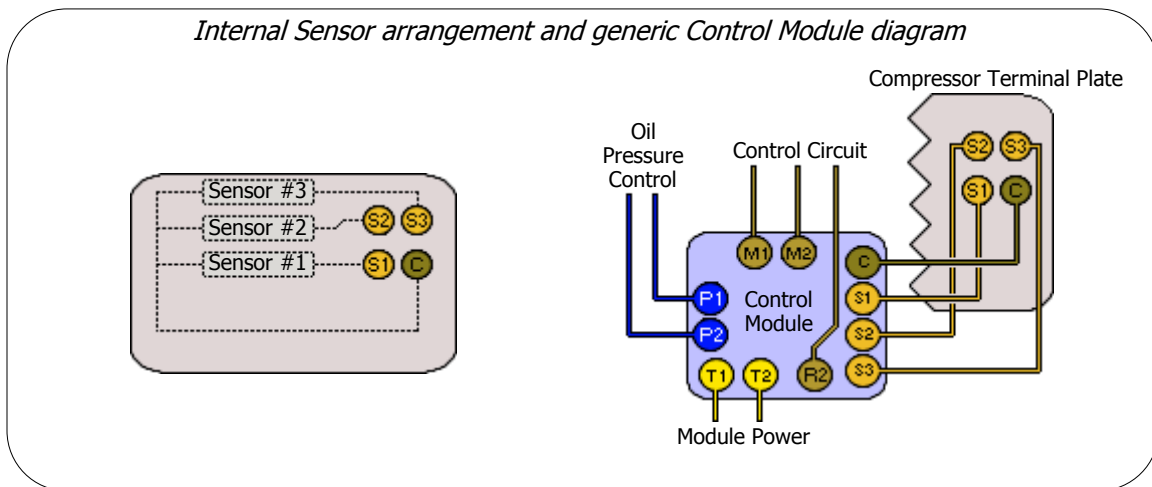
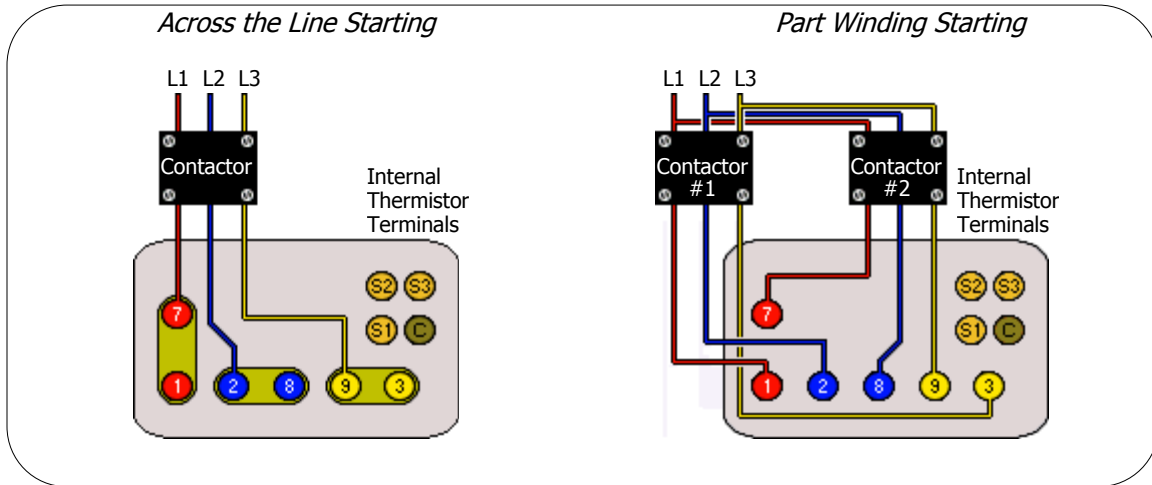

Use an ohmmeter with no more than 3 volt batteries. Check resistance from common terminal to each of the other sensor terminals. The module trip point is 100 ohms. Each sensor should read between 65 and 105 ohms depending on their temperature. If an internal sensor should fail it may be bypassed using a 75 - 80 ohm 1/4 watt resistor. This will reduce the effectiveness of the electronic motor protection system but will allow the compressor to operate.