

**York  
Model Z Compressors  
Terminal Wiring Diagrams**

***Across the Line Starting***

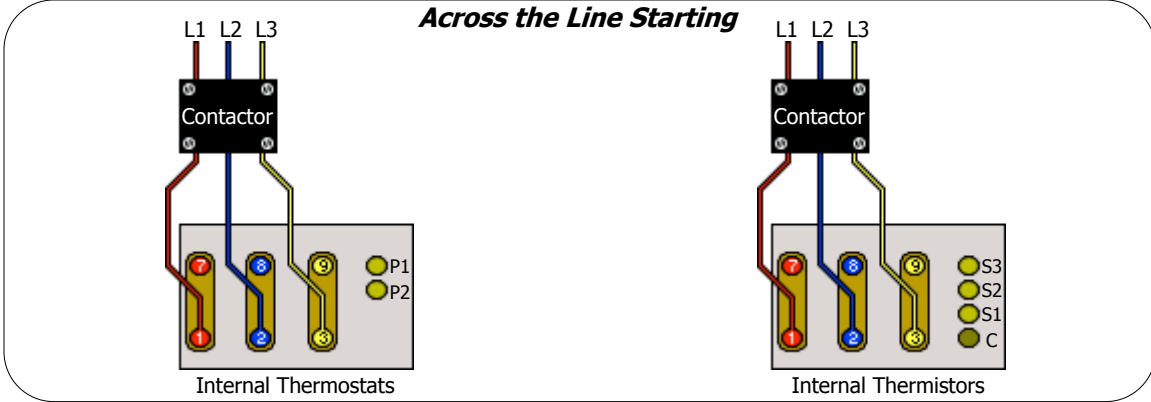

***Part Winding Starting***

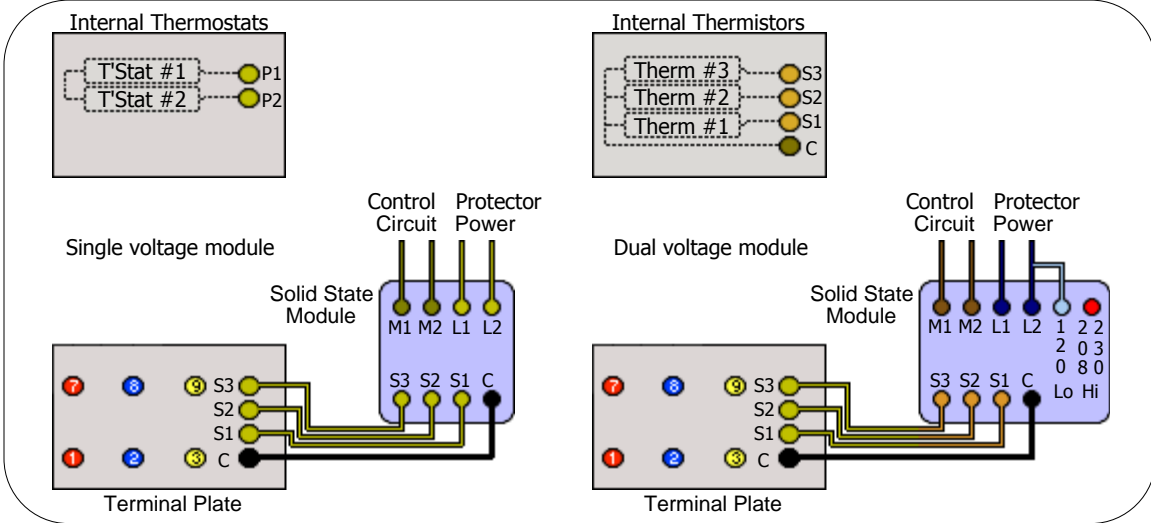
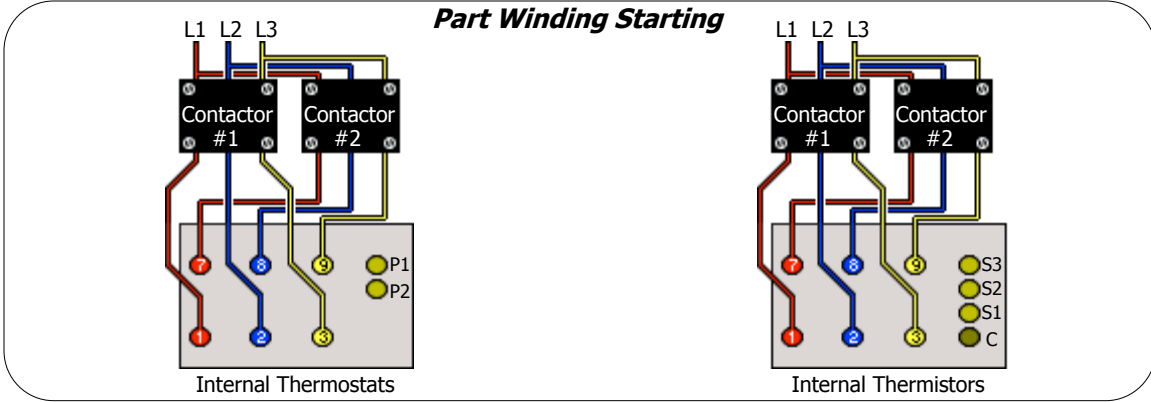

Internal thermistors should be checked with an ohmmeter. The resistance should be between 65 and 105 ohms depending on their temperature. Module trip point is 100 ohms.

With the dual voltage module connect jumper from Lo to L2 for 120 volts or from Hi to L2 for 208-230 volts. Terminals C and L1 are internally common and at the same voltage.